

LOC	DIST	REVISIONS					
GP	00	P	LTN	DESCRIPTION	DATE	DWN	APVD
		2		PRELIMINARY	20JUN2011	AL	CW
		3		REVISED PER ECO-14-018993	3MAR2015	RG	MC

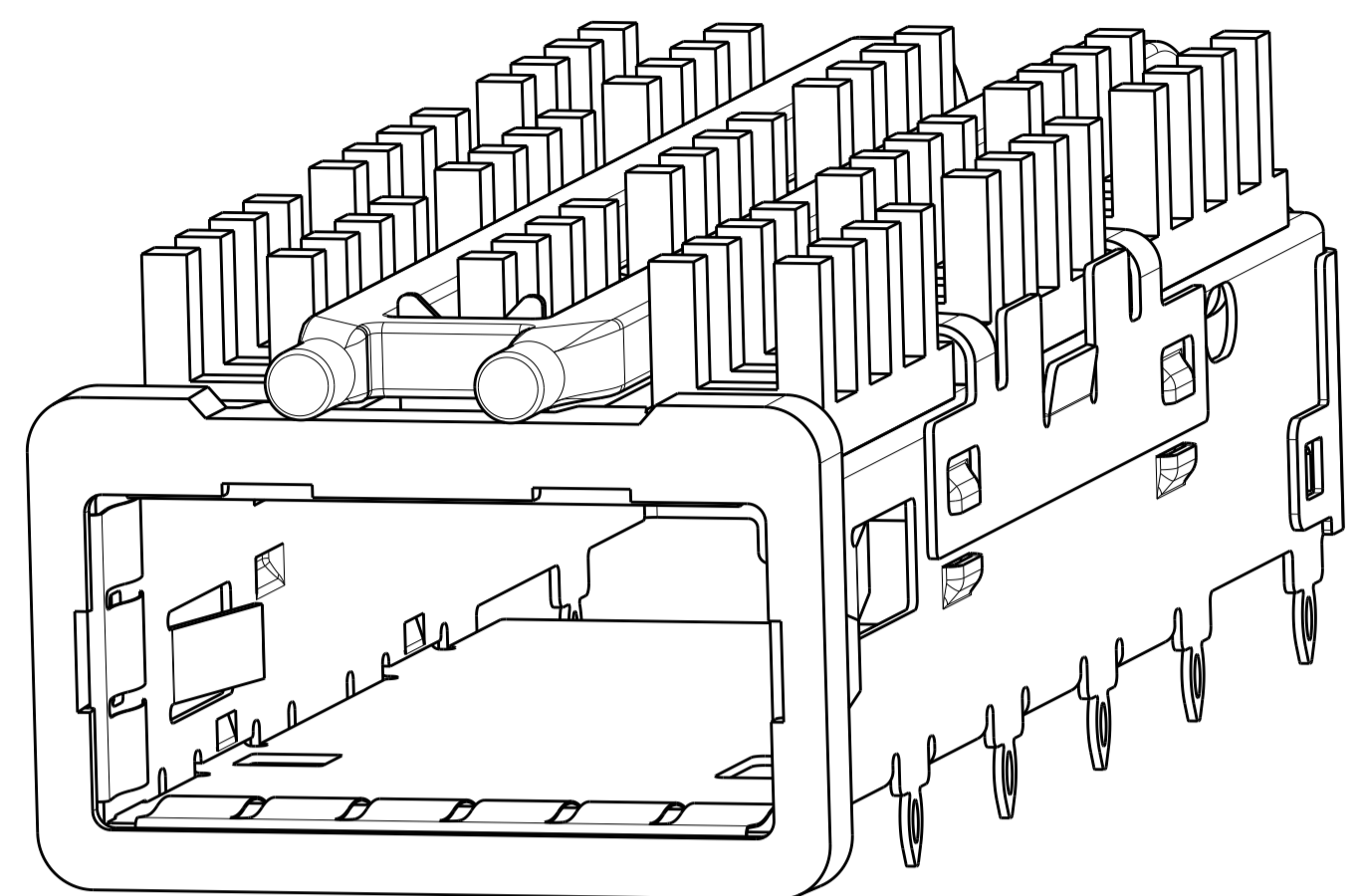

- △ CAGE MATERIAL: NICKEL SILVER, 0.25 THICK
 HEAT SINK MATERIAL: ALUMINUM
 HEAT SINK CLIP MATERIAL: STAINLESS STEEL
 EMI SPRING MATERIAL: COPPER ALLOY
 FRONT FLANGE MATERIAL: ZINC ALLOY
- △ MINIMUM PITCH DIMENSION.
- 3. MATES WITH QSFP MSA COMPATIBLE TRANSCEIVER.
- △ REFERENCE APPLICATION SPEC 114-13218 FOR RECOMMENDED DRILL HOLE DIAMETER AND PLATING THICKNESS.
- △ DATUMS AND BASIC DIMENSIONS ESTABLISHED BY CUSTOMER.
- △ DIMENSION C IS THE NOMINAL THICKNESS OF CUSTOMER SUPPLIED PC BOARD.
 SINGLE SIDED PC BOARD MINIMUM THICKNESS: 1.45
 DOUBLE SIDED PC BOARD MINIMUM THICKNESS: 2.7.
- △ HEAT SINK AND CLIP AND LIGHT PIPE SHIPPED ASSEMBLED TO CAGE ASSEMBLY CAGE ASSEMBLY MAY BE PRESSED INTO THE PCB AS SHIPPED.
- △ DATUM -A- IS TOP SURFACE OF HOST BOARD.
- △ SURFACE TRACES PERMITTED WITHIN THIS AREA EXCEPT WHERE CAGE STANDOFFS, SHOWN IN DETAIL J, CONTACT PC BOARD.
- △ DIMENSION APPLIES WITH MODULE INSTALLED IN THE CAGE.
- △ DATE CODE (YYWW) MARKED ON TOP OF CAGE AND CONCEALED BY HEAT SINK APPLIES TO CAGE ASSEMBLY ONLY.
- △ EMI SPRING FINISH: 2um MIN TIN.
 FRONT FLANGE FINISH: 3um MIN TIN OVER 1.27um MIN NICKEL OVER 5.08um MIN COPPER.
 HEAT SINK FINISH: 0.076um MIN NICKEL PLATING.
- 13. PRODUCT HAS NOT COMPLETED QUALIFICATION TESTING.

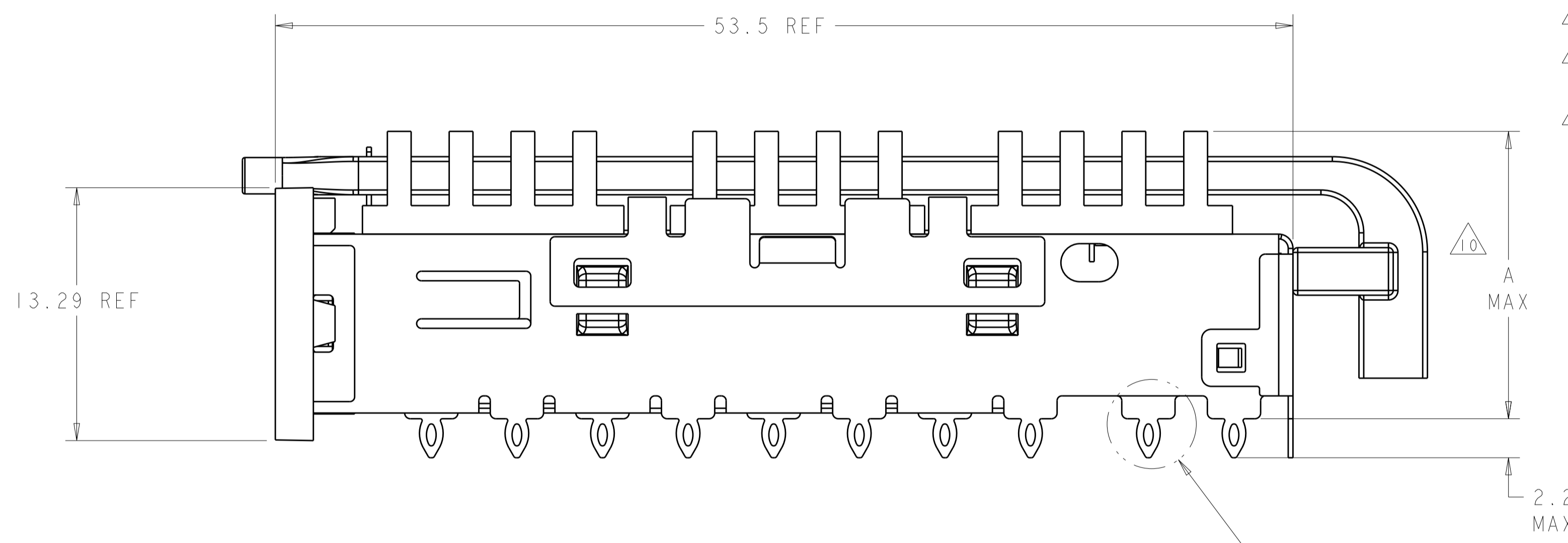
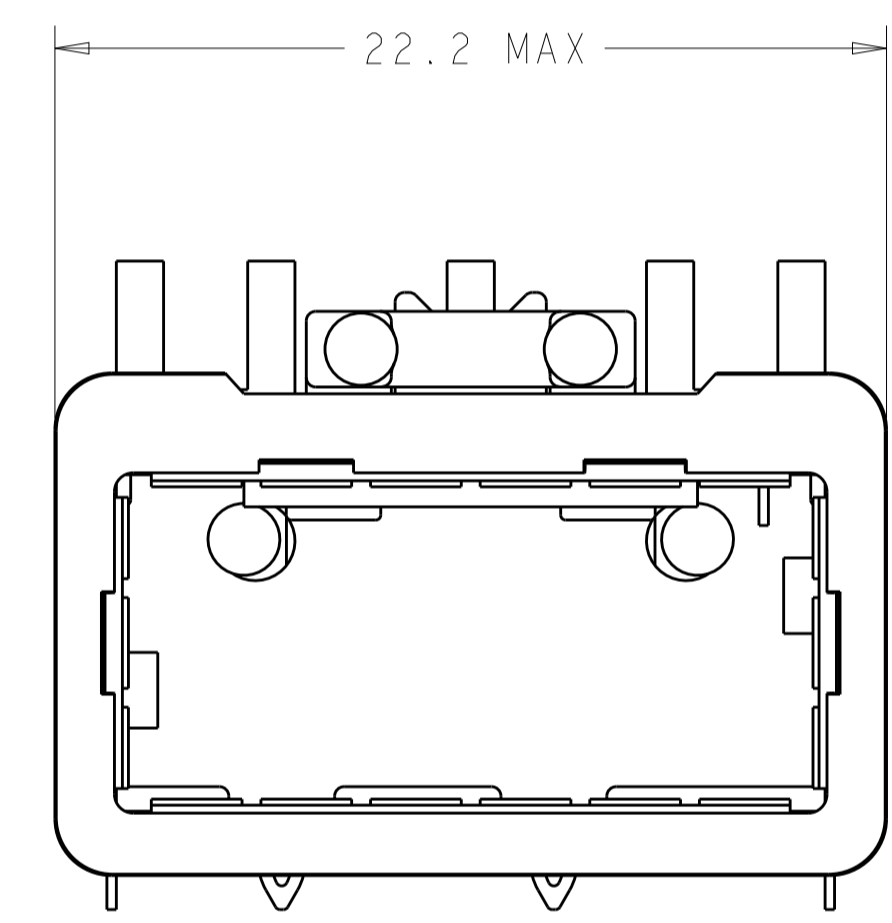

2170112-2 AS SHOWN

SEE DETAIL J

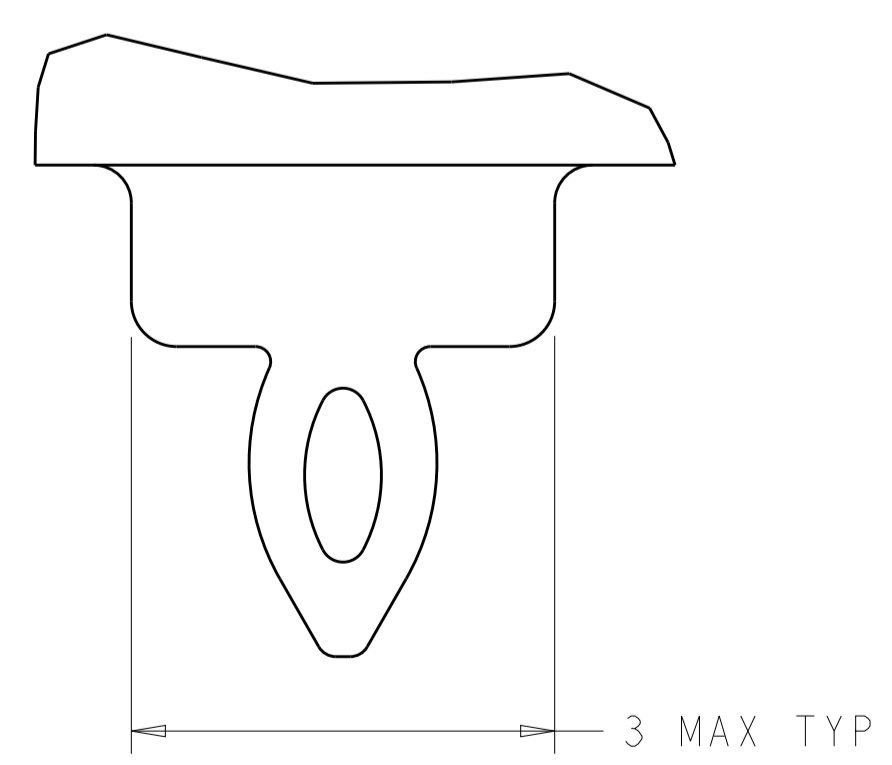

DETAIL J △
 SCALE 20:1

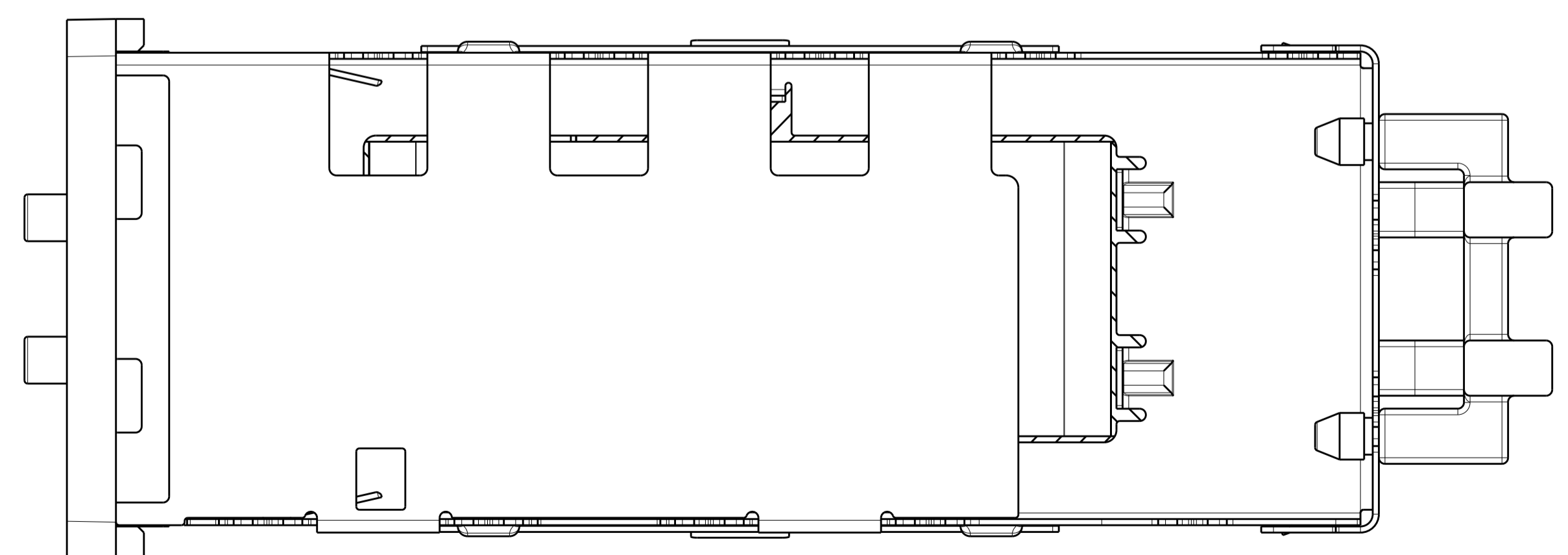

23.0	NETWORKING HEAT SINK	2170112-3
16.0	SAN HEAT SINK (SHOWN)	2170112-2
13.7	PCI HEAT SINK	2170112-1
A	DESCRIPTION	PART NUMBER

THIS DRAWING IS A CONTROLLED DOCUMENT.		DWN: AL 27MAY2011	STE TE Connectivity	
DIMENSIONS: mm		CHK: TX 27MAY2011		
TOLERANCES UNLESS OTHERWISE SPECIFIED:		APVD: CW 27MAY2011	NAME: 1X1 CAGE ASSEMBLY, BEHIND BEZEL WITH HEAT SINK AND DUAL LIGHT PIPE QSFP	
0 PLC ±0.5	1 PLC ±0.13	PRODUCT SPEC 108-2286	SIZE: CAGE CODE DRAWING NO. RESTRICTED TO	
2 PLC ±0.013	3 PLC ±0.001	APPLICATION SPEC 114-13218	A100779C=2170112	
4 PLC ±0.0001	ANGLES ±	WEIGHT	Customer Drawing	
FINISH		SCALE 5:1 SHEET 1 OF 5 REV 3		

LOC	DIST	REVISIONS					
GP	00	P.	LYR	DESCRIPTION	DATE	DWN	APVD
		-		SEE SHEET 1	-	-	-

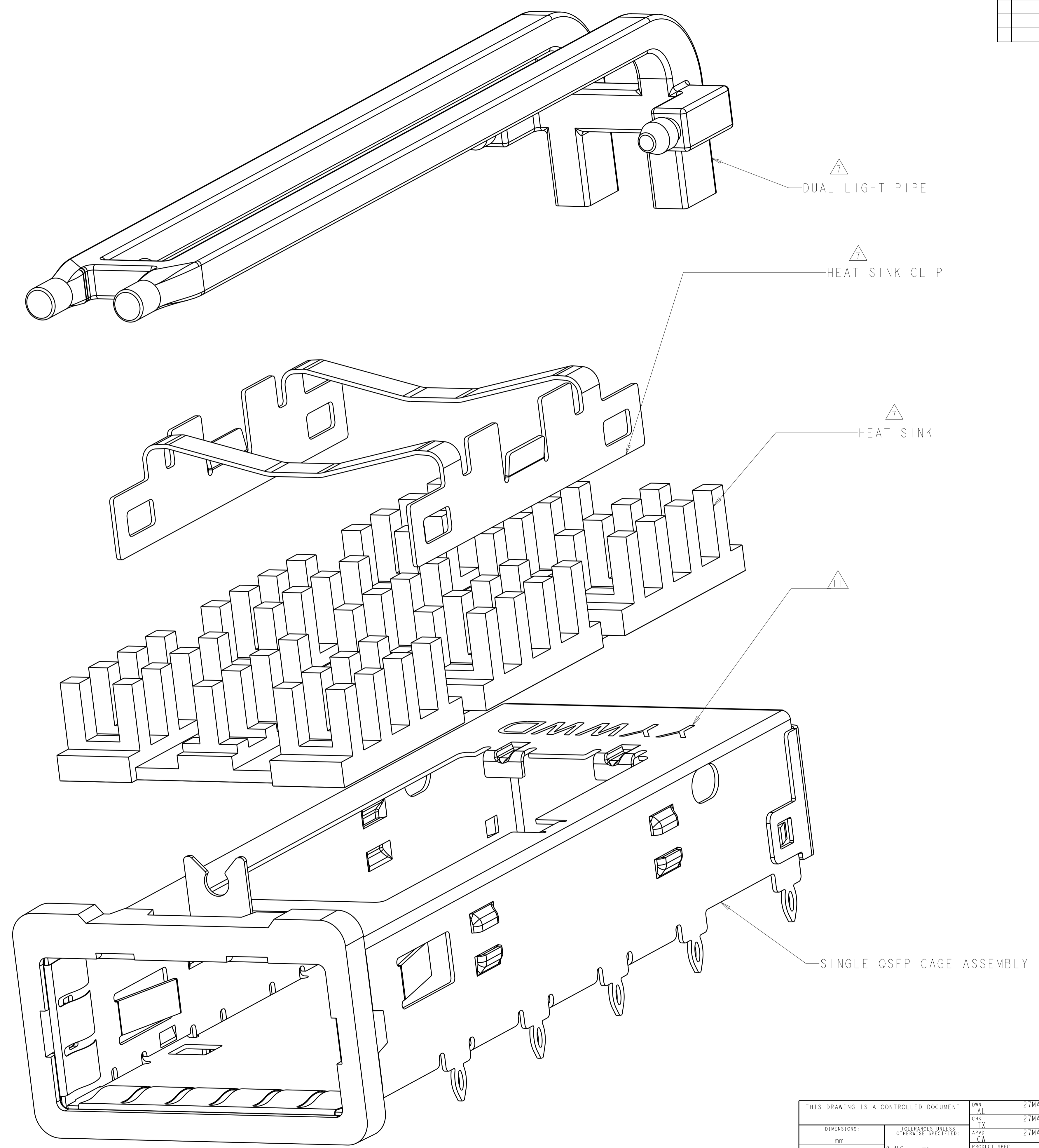

EXPLODED VIEW
 SCALE 8:1

THIS DRAWING IS A CONTROLLED DOCUMENT.		DWN: AL	27MAY2011	STE TE Connectivity
		CHK: TX	27MAY2011	
DIMENSIONS:		TOLERANCES UNLESS OTHERWISE SPECIFIED:		NAME: 1XI CAGE ASSEMBLY, BEHIND BEZEL WITH HEAT SINK AND DUAL LIGHT PIPE QSPF
mm		0 PLC ±0.5		
		2 PLC ±0.13		PRODUCT SPEC: 108-2286
		3 PLC ±0.013		APPLICATION SPEC: 114-13218
		4 PLC ±0.0001		SIZE: CAGE CODE DRAWING NO: A100779C=2170112
		ANGLES ±0.0001		RESTRICTED TO: -
MATERIAL: -		FINISH: -		WEIGHT: -
		Customer Drawing		SCALE: 5:1 SHEET 2 OF 5 REV 3

LOC	DIST	REV	DATE	BY	APPD
GP	00				
REVISIONS					

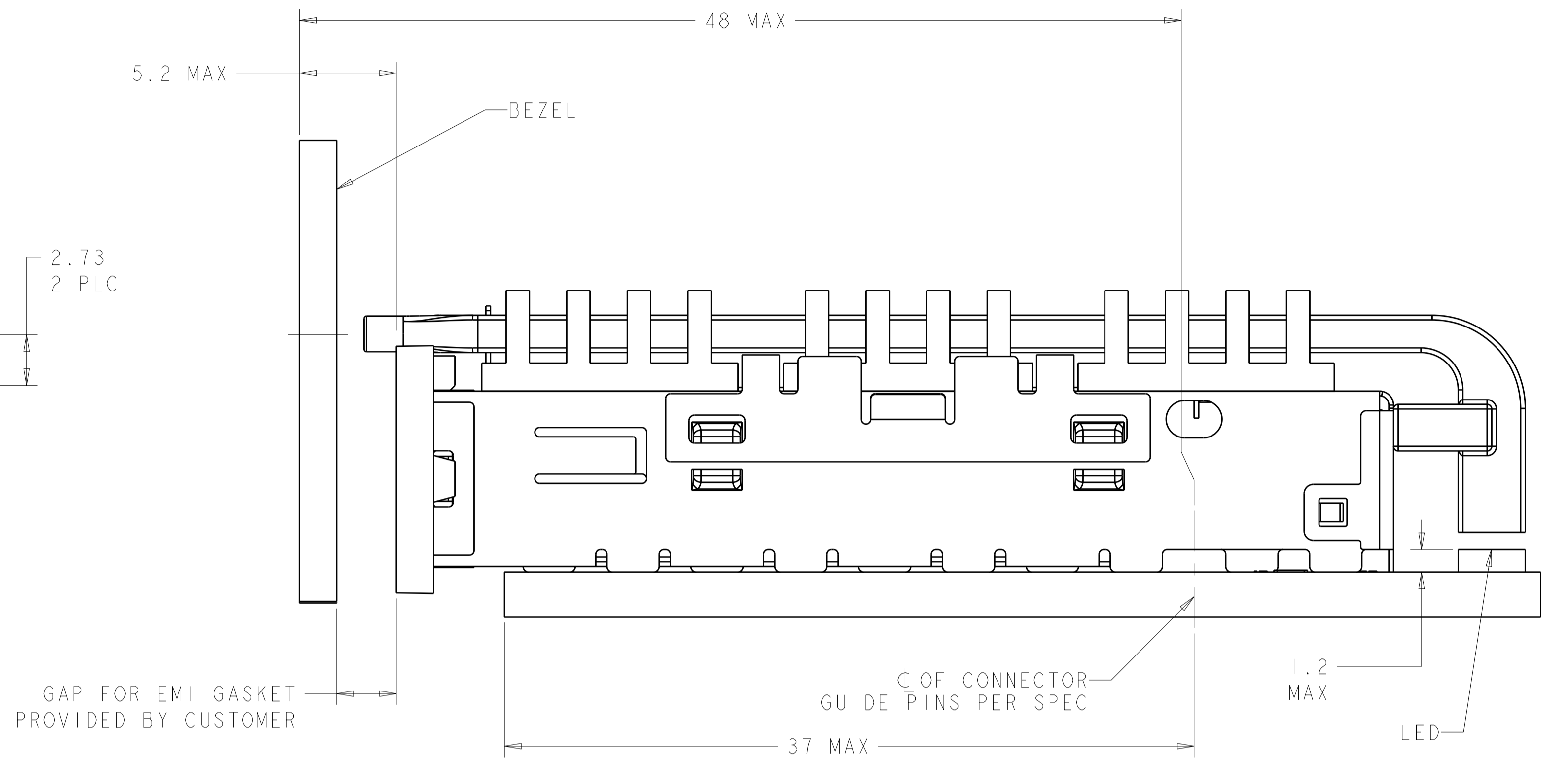
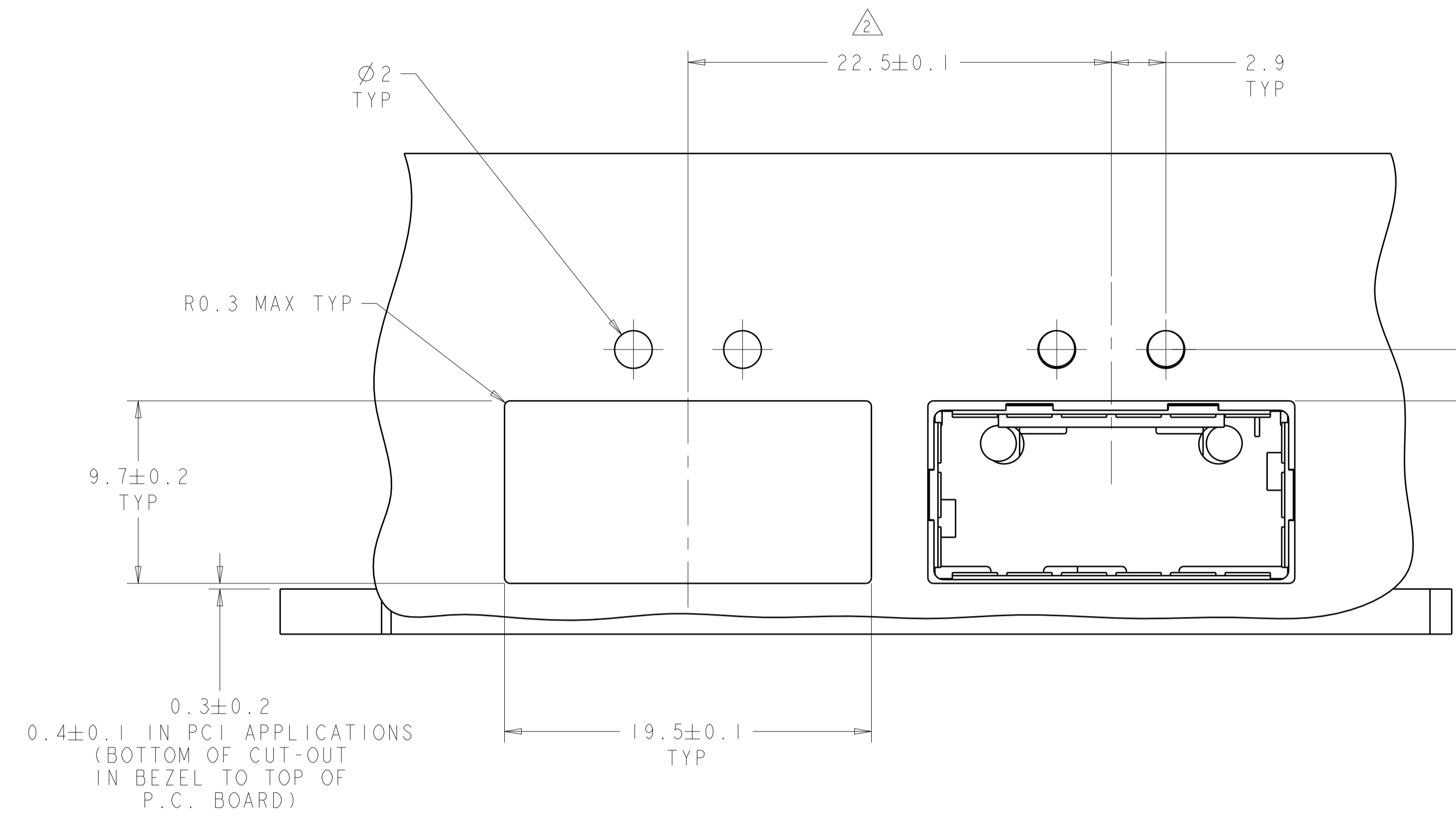

ONE SIDED CONFIGURATION

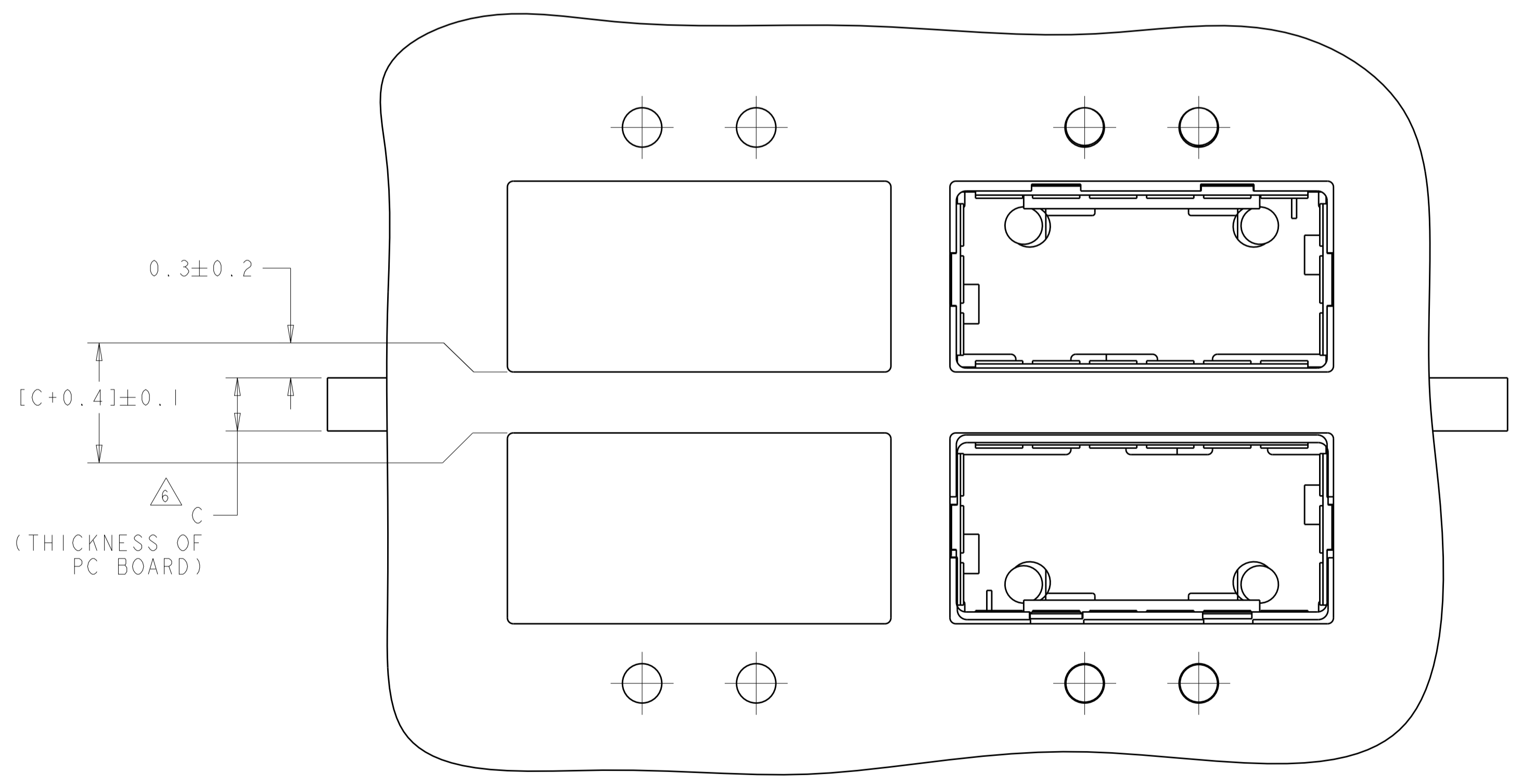

BELLY TO BELLY CONFIGURATION
 SIMILAR TO ONE SIDED EXCEPT
 WHERE NOTED

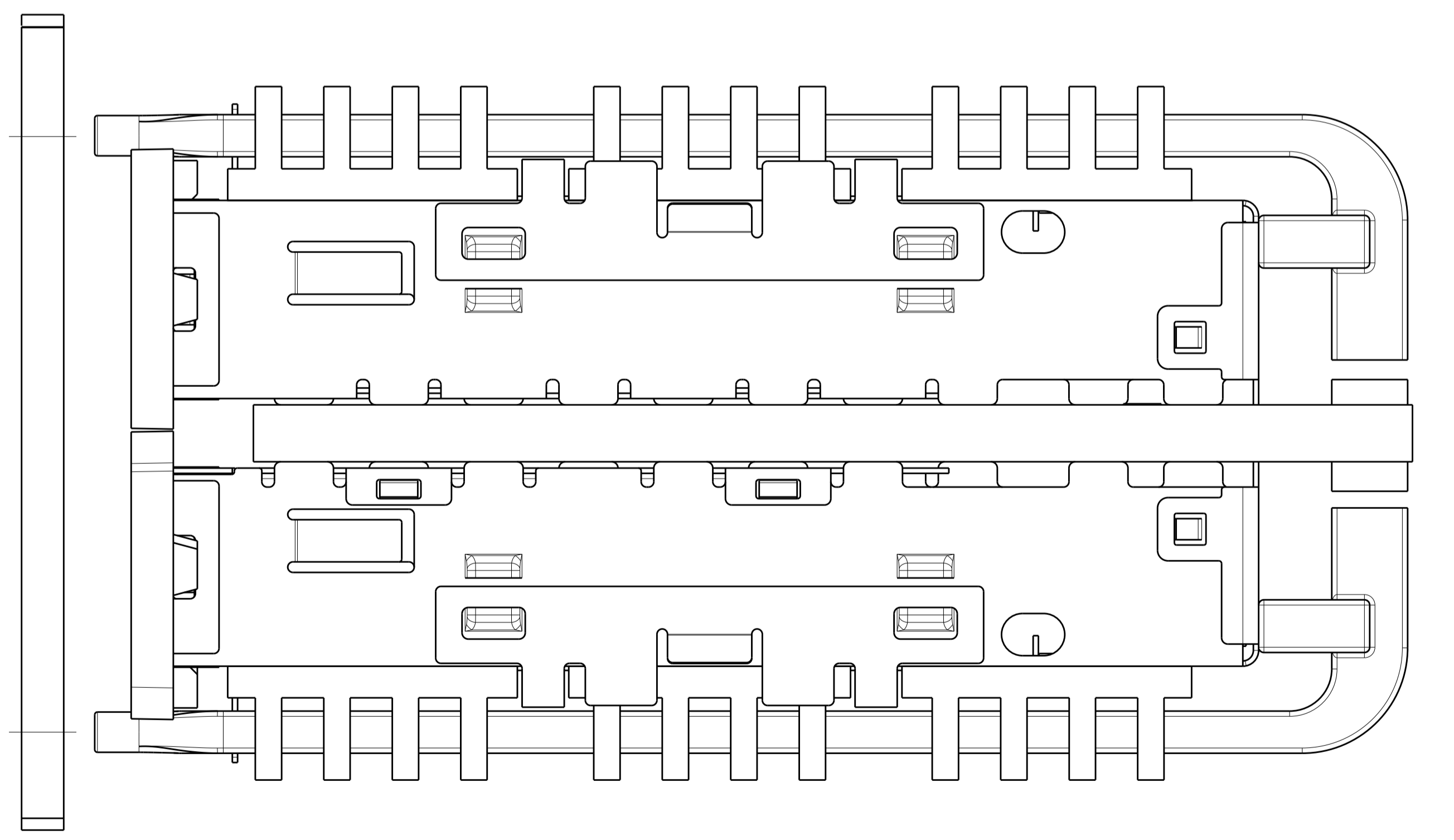

THIS DRAWING IS A CONTROLLED DOCUMENT.		OWN: JAL	27MAY2011	STE TE Connectivity
DIMENSIONS: mm		CHK: TX	27MAY2011	
TOLERANCES UNLESS OTHERWISE SPECIFIED:		APPD: CW	27MAY2011	NAME: 1XI CAGE ASSEMBLY, BEHIND BEZEL WITH HEAT SINK AND DUAL LIGHT PIPE QSFP
0 PLC ±0.5		PRODUCT SPEC		SIZE: CAGE CODE DRAWING NO
1 PLC ±0.13		108-2286		RESTRICTED TO
2 PLC ±0.13		APPLICATION SPEC		A100779C=2170112
3 PLC ±0.013		114-13218		SCALE: 5:1 SHEET 3 OF 5 REV 3
4 PLC ±0.0001		WEIGHT		Customer Drawing
ANGLES ±0.0001		FINISH		

LOC	DIST	REV	DATE	BY	APPD
GP	00				

REVISIONS			
REV	DATE	BY	APPD
-	-	-	-
-	-	-	-

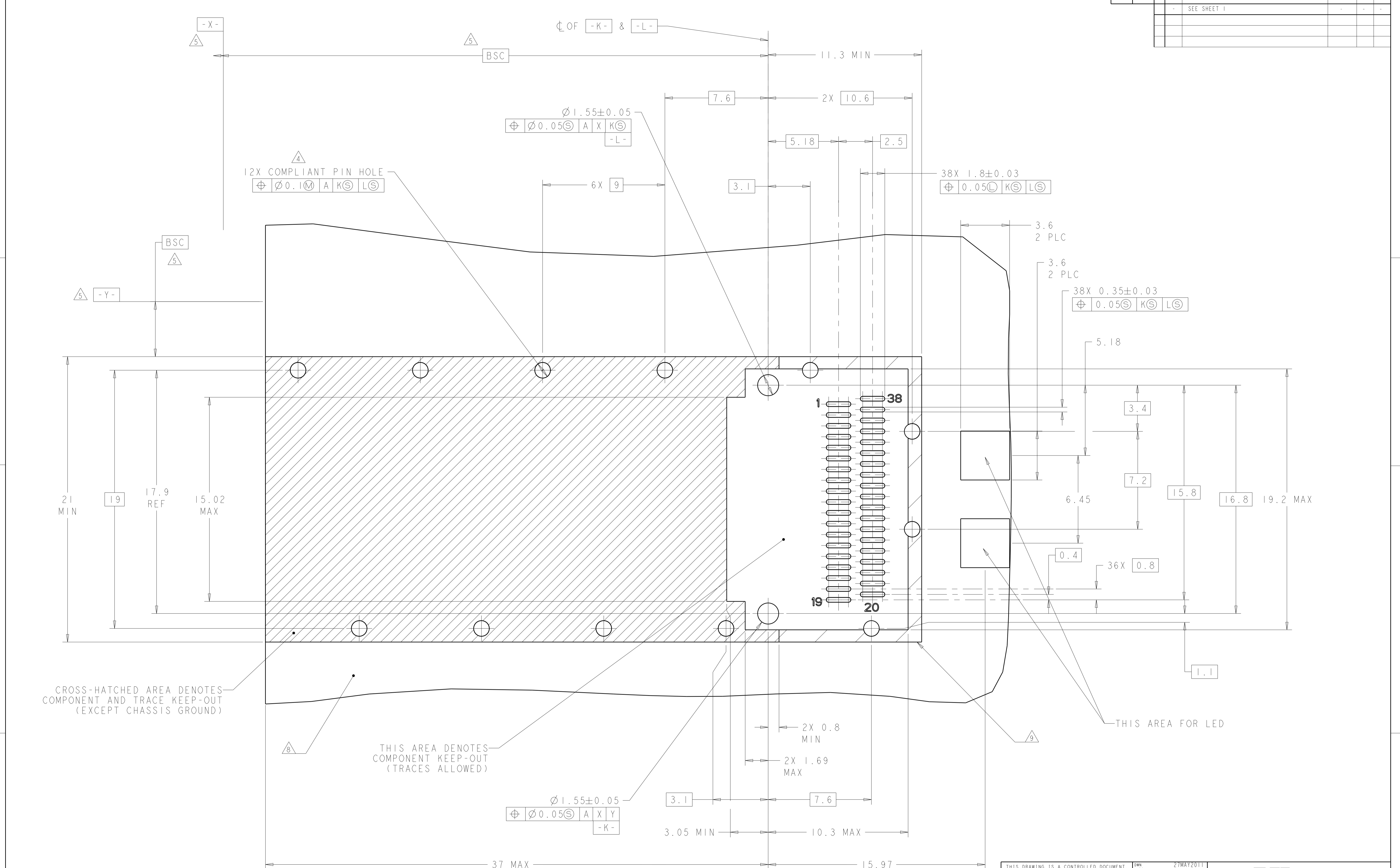

CROSS-HATCHED AREA DENOTES COMPONENT AND TRACE KEEP-OUT (EXCEPT CHASSIS GROUND)

THIS AREA DENOTES COMPONENT KEEP-OUT (TRACES ALLOWED)

THIS AREA FOR LED

RECOMMENDED PCB LAYOUT
 SINGLE SIDED CONFIGURATION
 SCALE 8:1

THIS DRAWING IS A CONTROLLED DOCUMENT.		OWN: 27MAY2011	 TE Connectivity
		CHK: 27MAY2011	
DIMENSIONS: mm		APPD: 27MAY2011	NAME: 1XI CAGE ASSEMBLY, BEHIND BEZEL WITH HEAT SINK AND DUAL LIGHT PIPE QSFP
TOLERANCES UNLESS OTHERWISE SPECIFIED:		PRODUCT SPEC: 108-2286	SIZE: CAGE CODE DRAWING NO: A100779C=2170112
0 PLC ±0.5		APPLICATION SPEC: 114-13218	RESTRICTED TO: -
1 PLC ±0.13		WEIGHT: -	SCALE: 4:1 SHEET 4 OF 5 REV 3
2 PLC ±0.013		MATERIAL: -	
3 PLC ±0.013		FINISH: -	
4 PLC ±0.0001			
ANGLES ±0.0001			

LOC	DIST	REV	DATE	DWN	APVD
GP	00				
		P. LTH	DESCRIPTION	DATE	DWN
		-	SEE SHEET 1	-	-

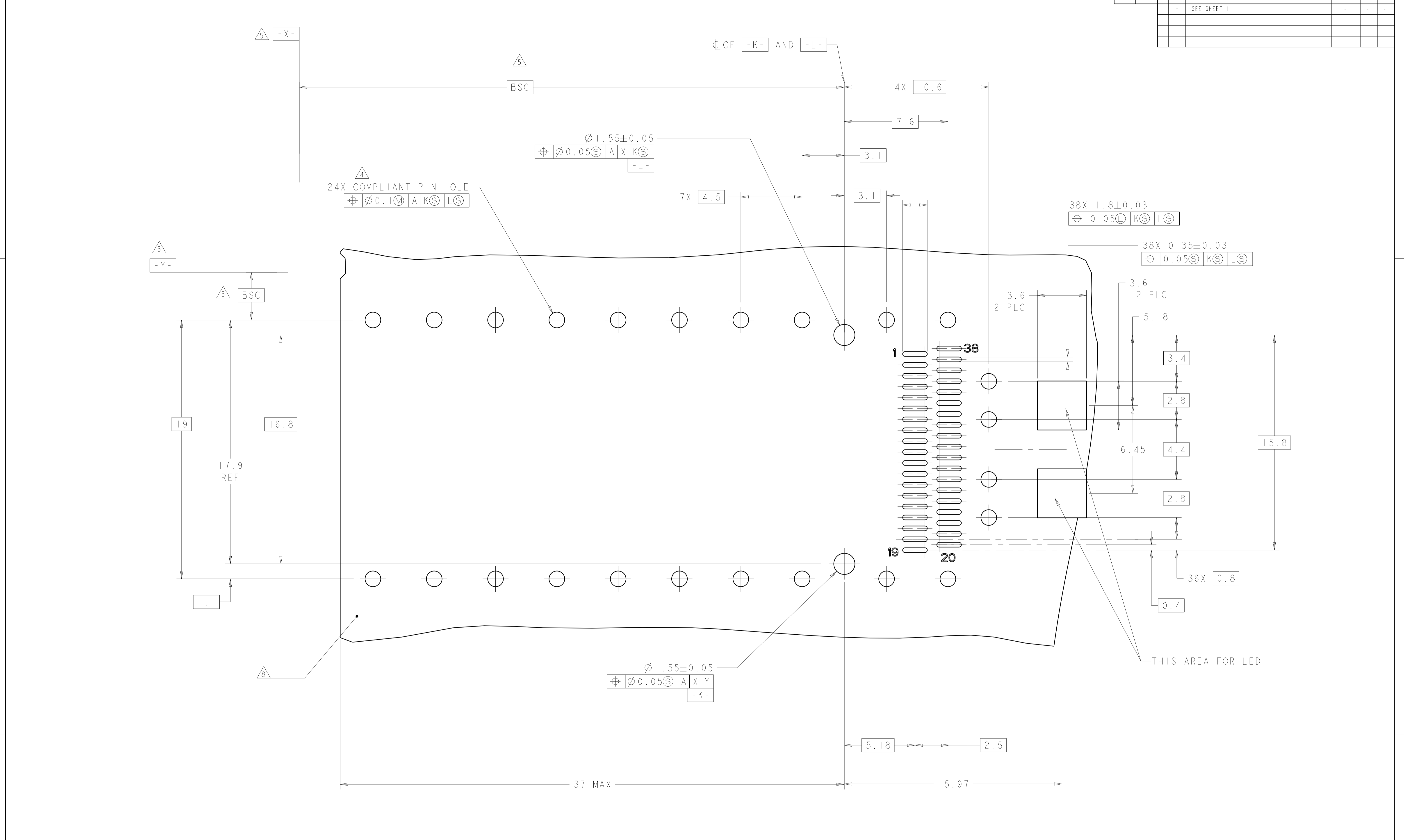

RECOMMENDED PCB LAYOUT
 BELLY TO BELLY CONFIGURATION
 SEE SHEET 4 FOR KEEP OUT AREAS
 SCALE 8:1

THIS DRAWING IS A CONTROLLED DOCUMENT.		DWN	27MAY2011		TE Connectivity
		CHK	27MAY2011		
		APPD	27MAY2011	NAME 1X1 CAGE ASSEMBLY, BEHIND BEZEL WITH HEAT SINK AND DUAL LIGHT PIPE QSFP	
		CW			
DIMENSIONS:		TOLERANCES UNLESS OTHERWISE SPECIFIED:		PRODUCT SPEC	
mm				108-2286	
 0 PLC ± 0.5 1 PLC ± 0.13 2 PLC ± 0.03 3 PLC ± 0.013 4 PLC ± 0.001 ANGLES ± 0.0001				APPLICATION SPEC	
MATERIAL		FINISH		114-13218	
				WEIGHT	
				Customer Drawing	
				SIZE CAGE CODE DRAWING NO RESTRICTED TO	
				A100779C=2170112	
				SCALE 4:1 SHEET 5 OF 5 REV 3	